

# Scandia SC440 Prime Operating table



**LOJER**<sup>®</sup> *For easy care*





## Lojer Group – Over 30 years of experience in operating tables

The quality of Lojer operating tables is highly regarded by customers around the world. Lojer operating tables are manufactured in Finland with decades of expertise. Usability, patient safety, ergonomic working and easy cleaning are the cornerstones of our product design philosophy. Combined with user-oriented product development and professional service Lojer operating tables represent first-class cost-effectiveness for the customer.

[www.lojer.com](http://www.lojer.com)





## Scandia SC440 Prime With an excellent price-quality ratio

The Scandia SC440 Prime is an excellent choice when you are looking for a high-quality and versatile operating table for day and short-stay surgery. The table has all the functionalities and versatility that is required in surgical procedures - and with an excellent price-quality ratio.

As an example of high quality the new motor technique allows simultaneous movements of different sections when using pre-programmed or zero position – making it faster to adjust the table.







**Scandia SC440 Prime**  
**Functional design**

The Scandia SC440 Prime proves that elegant design can also be practical. The electric operating table is carefully designed to provide maximum efficiency and more room for the surgical team to operate. The functional and smart frame construction enables easy cleaning and high level of hygiene – for example, all splatters are led on the floor by the frame.

Due to smart and clear structure the Scandia SC440 Prime is also fast and easy to maintain.



## Scandia SC440 Prime Versatile surgery positions

The sliding table-top structure together with modular parts enable a wide range of different surgery positions including flex and reflex positions. Combined with a wide range of accessories the Lojer Scandia SC440 Prime ensures ergonomic and anatomically best posture position for the patient.

The table features four programmable memory positions and zero position.





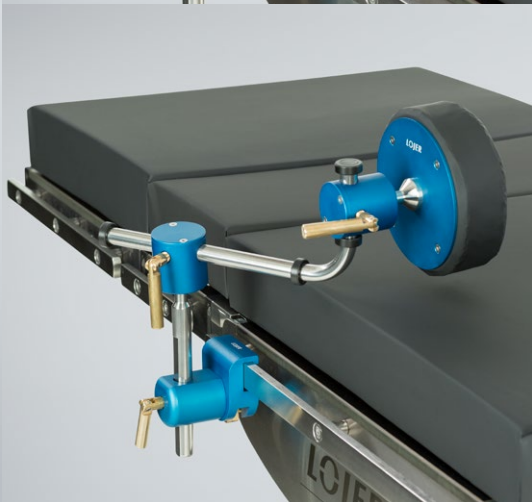
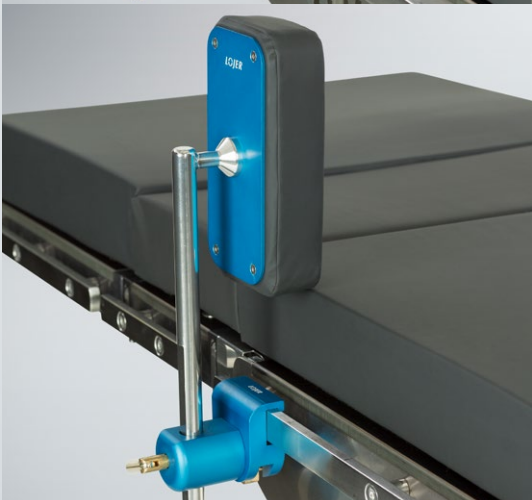
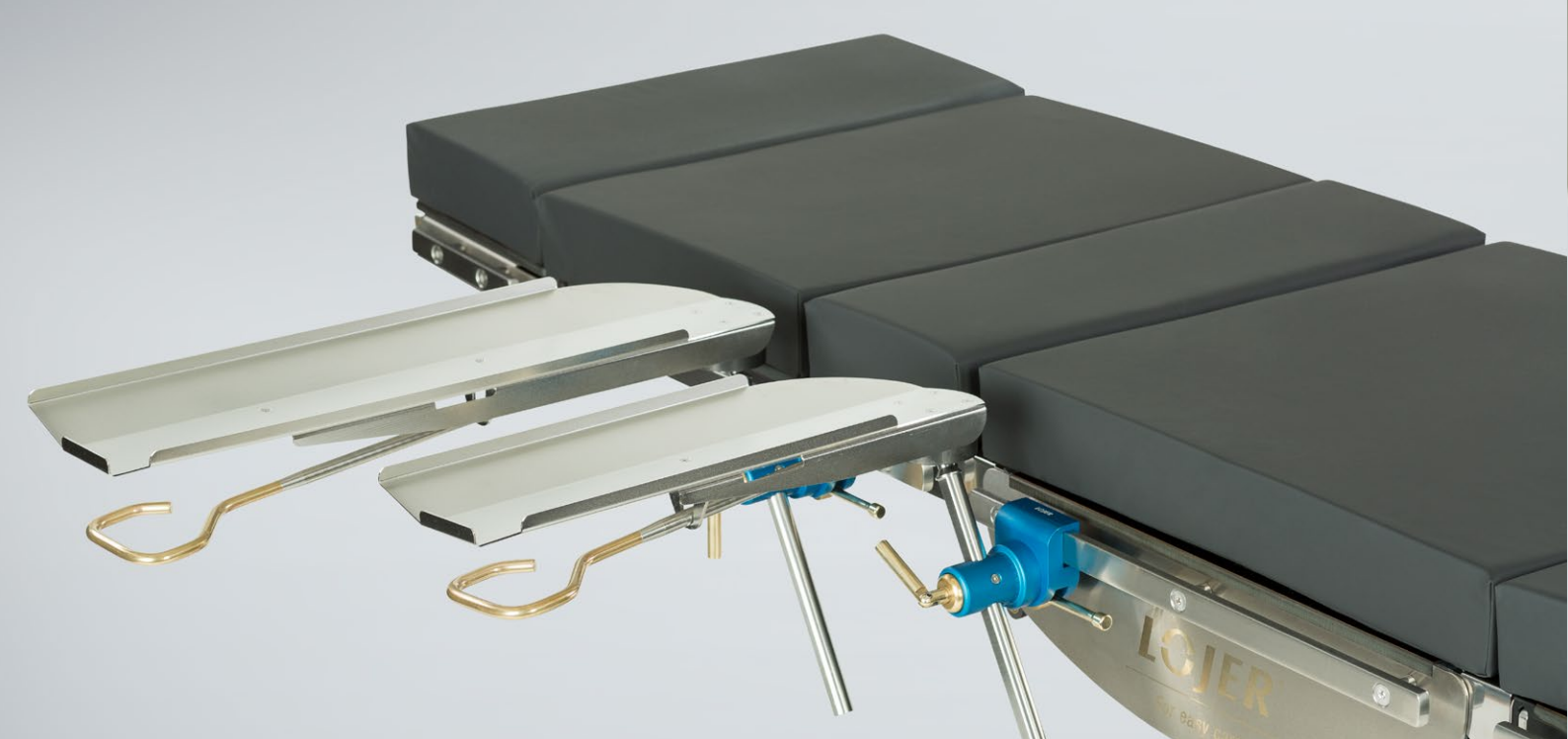

## Quality guarantee

The Scandia SC440 Prime operating tables are manufactured in Finland in our state-of-art-manufacturing facility in accordance with current standards. Certified ISO 9001 since 1994 and ISO 13485 quality systems are a promise of the responsible action of Lojer Group. Our products undergo a final inspection before delivery to the customer to ensure that they meet the highest requirements. All our products are CE-marked – a sign of our quality, responsibility and commitment to safety.



Take a look at the Operating table accessories catalogue as well!



EXAMPLES OF SURGERY POSITIONS

Arm and hand surgery,  
supine position



Knee arthroscopy,  
supine position



ENT / plastic / eye surgery,  
supine position



Spinal surgery,  
prone position



LOJER® For easy care

Gynaecology and urology surgery,  
lithotomy position











**Scandia SC440 Prime**  
Technical data

Total length	2070 mm
Width incl. side rails	622 mm
Mattress width	550 mm
Total weight	200 kg
Safe Working Load (SWL)	250 kg
Height adjustment range	595-1005 mm
Castors	Four Ø 125 mm central locking twin castors
Head section	-58° ... +37°, 135 mm
Back section	-10° ... +70°
Leg section	-80° ... +10°
Lateral tilt	20° / 20°
Trendelenburg / Anti-Trendelenburg	30° / 20°
Slide (optional)	300 mm
Flex / reflex	220° / 120°
Electrical system	24 VDC, battery operated 100 - 240 VAC, 50/60 Hz
Controls	Hand control and integrated control panel on the column
Memory positions	Four programmable positions
Warranty	2 years
Country of manufacture	Finland
CE-marked	Yes

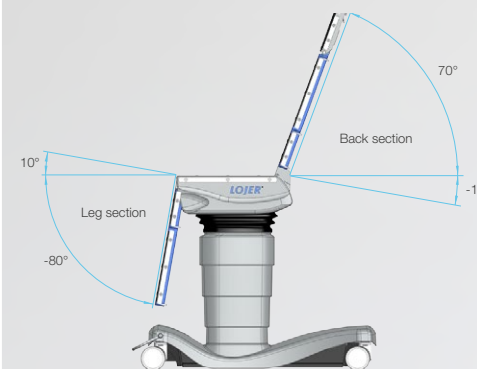
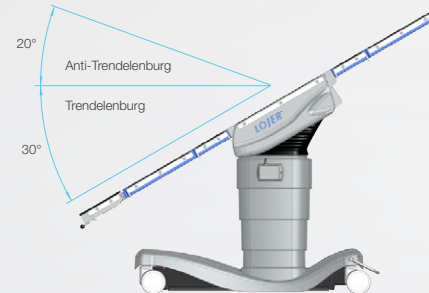
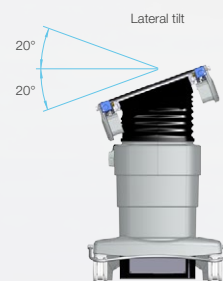
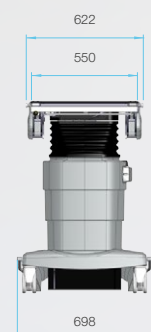
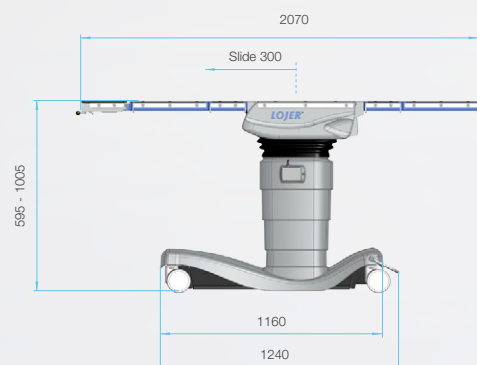

Possible variation ±2° / ±5 mm / ±5 kg

Lojer reserves the right for product modifications.





Tels.: (33) 15-78-28-02 / 15-68-16-02

[www.alpinemedica.com](http://www.alpinemedica.com)

## **LOJER**<sup>®</sup> *For easy care*

Lojer Group is the largest manufacturer of medical and healthcare equipment in the Nordic countries. In our two factories in Finland, we manufacture products such as hospital beds, operating tables, examination tables and treatment tables. The company is 100 years old and still privately owned. Lojer products are used in over 110 countries.

[www.lojer.com](http://www.lojer.com)

© Lojer Group 2018. All rights reserved

Lojer Group, Putajantie 42, 38210 Sastamala Finland

Tel. + 358 10 830 6700 | [info@lojer.com](mailto:info@lojer.com) | [www.lojer.com](http://www.lojer.com)